

# Disegna 5.0

design software

***NEW SYSTEMS***

# 0. Index

<b>1. Installation</b>	4 - 6
<b>2. The User Interface</b>	7
Application menu	8
The Ribbon	8 - 9
Tool Palettes	9 - 10
Drawing Area	10 - 11
ViewCube	11
<b>3. Menu shortcuts</b>	12
<b>4. Drawing with Disegna</b>	13
<b>5. Onboarding</b>	14
<b>6. Starting to Draw</b>	15
Open or Save a Drawing	15
Repair, Restore, or Recover Drawing Files	15
<b>7. Referenced Drawing</b>	16
Attach Commands	16
Attach	16 - 17
Determine the Unit of Measurement	17
Scale Attach	17 - 19
Attach ON - Attach OFF	19 - 20
Erase Attach	20

<b>8.</b>	<b><i>Drawing a Perimeter</i></b>	21
	Ortho Mode	22
	Drawing a Perimeter Protection	22
	Adding Doors to the Perimeter	23
	Drawing a Door	23 - 25
	Drawing Custom Panels	25 - 26
	Making changes	27 - 30
<b>9.</b>	<b><i>Exporting a Bill of Materials</i></b>	31 - 32



# 1. Installation

Your copy of **Disegna 5.0** will be valid **for 90 days from activation**. Upon expiration of this period, you can request to extend the validity of your license and continue using the program for an **additional 365 days free of charge**.



## 1. Download the Software for free

Download Disegna 5.0 [from this page](#).

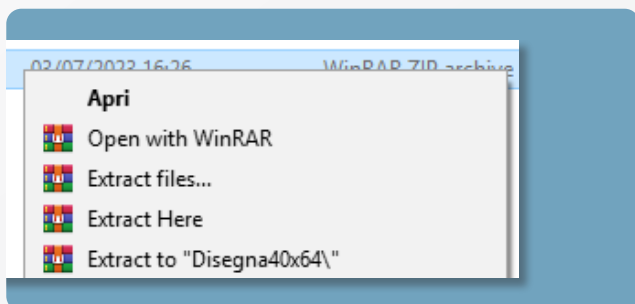

## 2. Extract the installer

Once the download is complete, **extract the downloaded file** in a sub-folder on your computer.

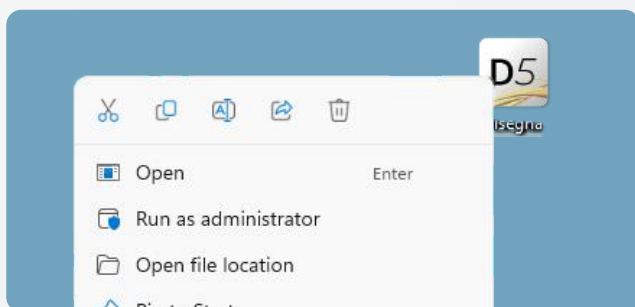

## 3. Install Disegna

Launch the **setup.exe** file on your computer by selecting the **"Run as administrator"** option (on Windows).



4.

## Fill the Form with your information

Enter all the required information in the registration window, then click "Submit".

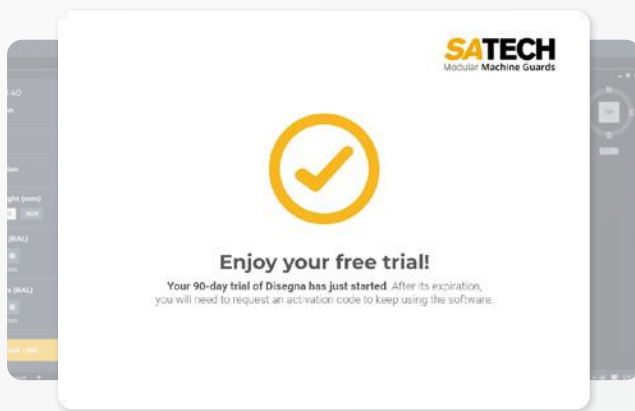

5.

## Get your free trial

Your license for a **90-day free trial** will be activated right away!

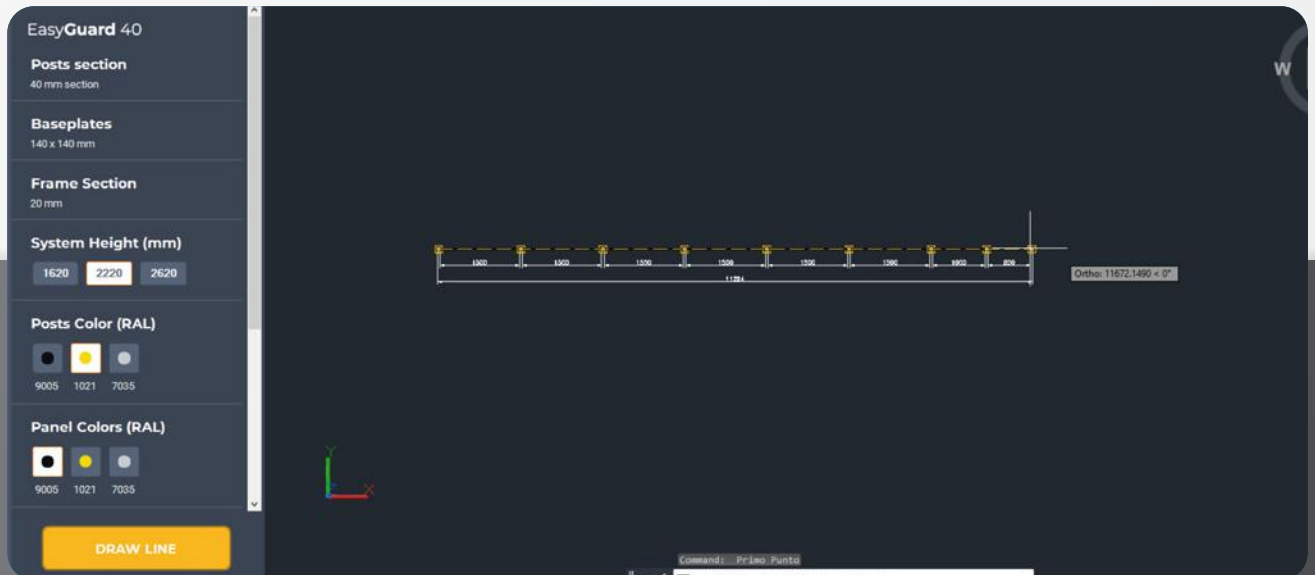

6.

## Start drawing

You'll be able to use **Disegna 5.0** to **design your Perimeter** with the entirety of **Satech modular components!**

## AFTER 90 DAYS

# License renewal

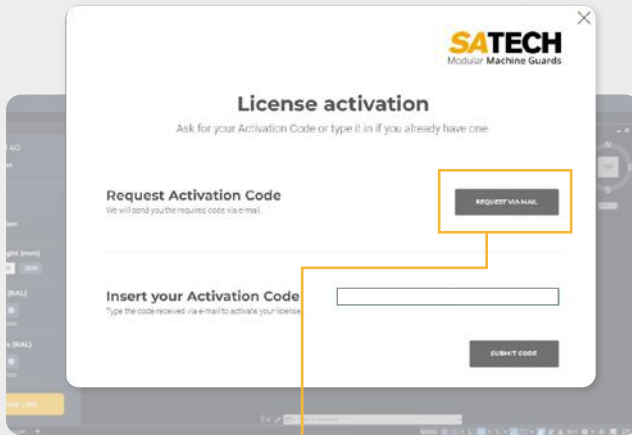

To extend the validity of your license beyond the 90th day, you will need to request a final code. To request it, click on the button **“Request via mail”** in the activation window.

*An email will be automatically generated to request the code, which will be sent to you in a few days.*



E0EA60-8A862F-46FDBA-3EC9B7-DAC2C4-072590



### **Enter the final code**

Once you receive the code, copy and paste it into the **activation window** and press the **“Activate”** button.

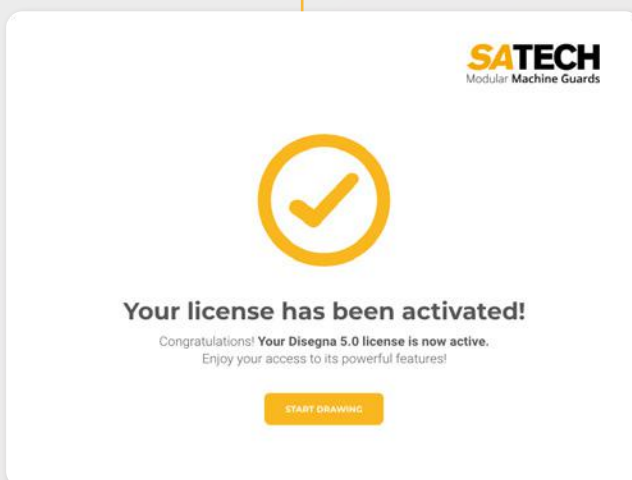

### **You're all set!**

Congratulations, **your license for Disegna 5.0 has been renovated for an additional 365 days!** Enjoy drawing your Perimeter Guarding with our components.

# 2. The User Interface

Disegna 5.0 comes with an interface that includes tools such as the Ribbon, Tool Palettes and ViewCube. This section presents an overview of the main interface tools and their functionalities.

## 1 Application menu

## 2 The Ribbon

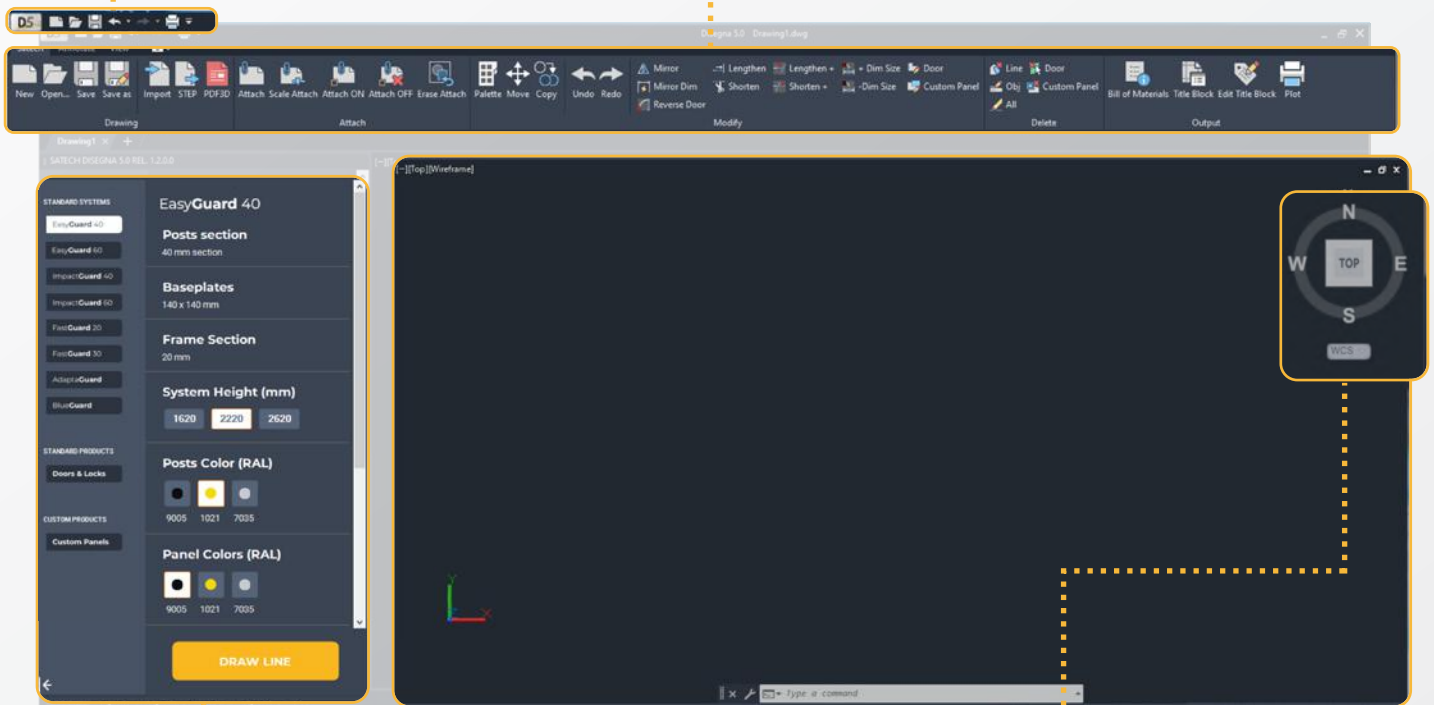

## 3 Tool Palettes

## 5 ViewCube

## 4 Drawing Area

## 7 Application menu

Access common tools to start or publish a file in the application menu.

Click the application button to quickly:

- Create, open or save a file
- Print or publish a file

## 2 The Ribbon

**The Ribbon is a palette that displays task-based tools and controls.**

The Ribbon is displayed horizontally or vertically. The horizontal Ribbon is displayed across the top of the file window. **You can dock the vertical Ribbon to the left or right of the file window.** The vertical Ribbon can also float in the file window or on a second monitor.

The Ribbon is composed of a series of panels, which are organized into tabs labeled by task. Ribbon panels contain many of the same tools and controls available in toolbars and dialog boxes. To minimize the Ribbon:

### FIRST BUTTON

The first button toggles the between full Ribbon state, the default Ribbon state, and the minimized Ribbon state.

### SECOND BUTTON

The second drop-down button allows you to select the minimize Ribbon state. These are the four minimize Ribbon states:

- **Minimize to Tabs:** minimizes the Ribbon so that only tab titles are displayed.
- **Minimize to Panel Titles:** minimizes the Ribbon so that only tab and panel titles are displayed.
- **Minimize to Panel Buttons:** minimizes the Ribbon so that only tab titles and panel buttons are displayed.
- **Cycle Through All:** cycles through all four Ribbon states in the order, full Ribbon, minimize to panel buttons, minimize to panel titles, minimize to tabs.



### 3 Tool Palettes

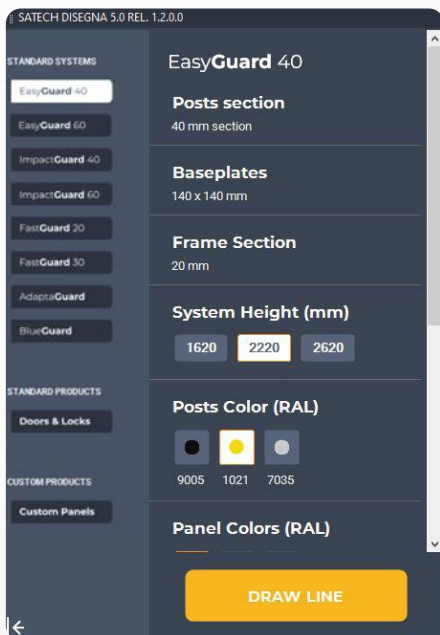

In **Disegna 5.0**, Tool Palettes provides the flexibility to have quick access to Drawings, Tools, and Commands etc. These can be docked, undocked, resize and move at different locations in UI. The Tool Palettes provide instant access to a complete inventory of **Disegna 5.0** tools, such as Panels, Posts and Doors in one consistent user interface.

Tool Palettes contain collections of tools and represent the individual tabs of a tool palettes group. **Disegna 5.0**'s Tool Palettes feature:

- Easy**Guard** 40
- Easy**Guard** 60
- Impact**Guard** 40
- Impact**Guard** 60
- Fast**Guard** 20
- Fast**Guard** 30
- Adapta**Guard**
- Blue**Guard**
- **Doors**
- **Custom Panels**

By clicking on each of these names, the user will access to the contextual Tool Palette.



## 4 Drawing Area

The Drawing Area is the zone of the software where you can draw your Perimeter Guarding. In the Drawing Area, the appearance of the cursor changes depending on what you are doing.

- If you are prompted to specify a point location, the cursor appears as **crosshairs**;
- If you are prompted to select an object, the cursor changes to a small square called a **pickbox**;
- when you are not in a command, the cursor appears as a combination of the crosshairs and pickbox cursors;
- If you are prompted to enter text, the cursor appears as a vertical bar.

Model / Layout1 / Layout2 / Layout3 / Layout4 / + /

### Model Space and layouts

There are two working environments - also called **Spaces** - in which you can work: the **Model Space** and **Paper Space** layouts.

- Model Space is used to create 2D drawings and 3D models;
- Paper Space is used create layouts for plotting.

While you can plot from Model Space, layouts are more convenient for scaling views, changing the location of views, and controlling the area and settings used in plotting.

To switch between Model Space and a layout, click the drop-down near the left side of the status bar.

[−][SW Isometric][Conceptual]

## Viewports control

Viewport controls are displayed at the top-left corner of each viewport, and provide a convenient way of changing views, visual styles, and other settings.

The labels display the current viewport settings. For example, the labels might read **[+] [Top] [2D Wireframe]**.

You can click within each of the three bracketed areas to change the settings.

- Click **[+]** to display options for maximizing the viewport, changing the viewport configuration, or controlling the display of navigation tools;
- Click **[Top]** to choose between several standard and custom views;
- Click **[2D] Wireframe** to choose one of several visual styles.

Most of the other visual styles are used for 3D visualization.

## 5 ViewCube



The ViewCube tool provides **visual feedback of the current orientation of a model**. You can use the ViewCube tool to adjust the viewpoint of the model. The ViewCube tool is a navigation tool that is displayed when you are working in 2D model space or 3D visual style and that allows you to switch between standard and isometric views.

When you display the ViewCube tool, it is shown in one of the corners of the window over the model in an inactive state.

The ViewCube tool provides visual feedback about the current viewpoint of the model as view changes occur. When the cursor is positioned over the ViewCube tool, it becomes active. You can drag or click the ViewCube tool, switch to one of the available preset views, roll the current view, or change to the Home view of the model.

# 3. Menu shortcuts

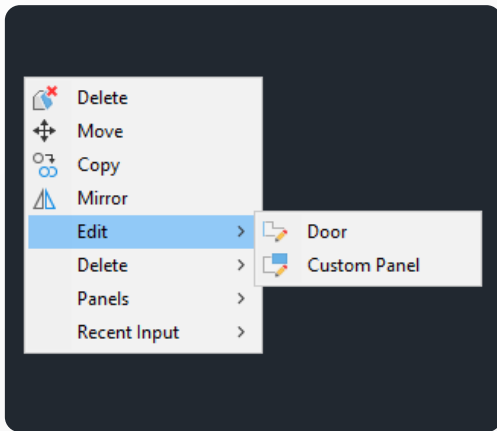

The software interface offers an **intuitive right-click short menu to enhance the user experience and streamline operations**. By right-clicking within the workspace, users can access a range of actions, ensuring quick adjustments without having to navigate through multiple toolbars or menus. Key options include:

- **Delete**: removes a selected item or element from the workspace.
- **Move**: enables users to reposition a selected item to a new location.
- **Copy**: allows duplication of a selected item, which can then be placed elsewhere.
- **Mirror**: provides a tool to create a mirrored version of a selected item, often useful for symmetrical designs or patterns.
- **Edit**: features a submenu that further branches into:
  - *Edit Door*: opens the editing mode specifically for door elements, allowing users to modify door properties.
  - *Edit Custom Panel*: grants access to the custom panel editor, facilitating bespoke design adjustments.
- **Panels**: this option provides an array of panel-related functionalities, though specific actions are not depicted in the provided image.
- **Recent Input**: grants users quick access to their recent actions or inputs, simplifying the process of redoing or adjusting recent modifications.

**This contextual menu is designed for efficiency**, placing essential tools and actions right at the user's fingertips. Whether you're designing, editing, or reviewing, the right-click menu ensures a seamless workflow.

# 4. Drawing with Disegna

The file extension for drawing files is **.dwg**.

Unless you change the default file format in which drawings are saved, drawings are saved in the latest drawing file format. This format is optimized for file compression and for use on a network.

The character limit for a .dwg file name (including its path) is **256 characters**.

The standard drawing unit is **millimeters**.

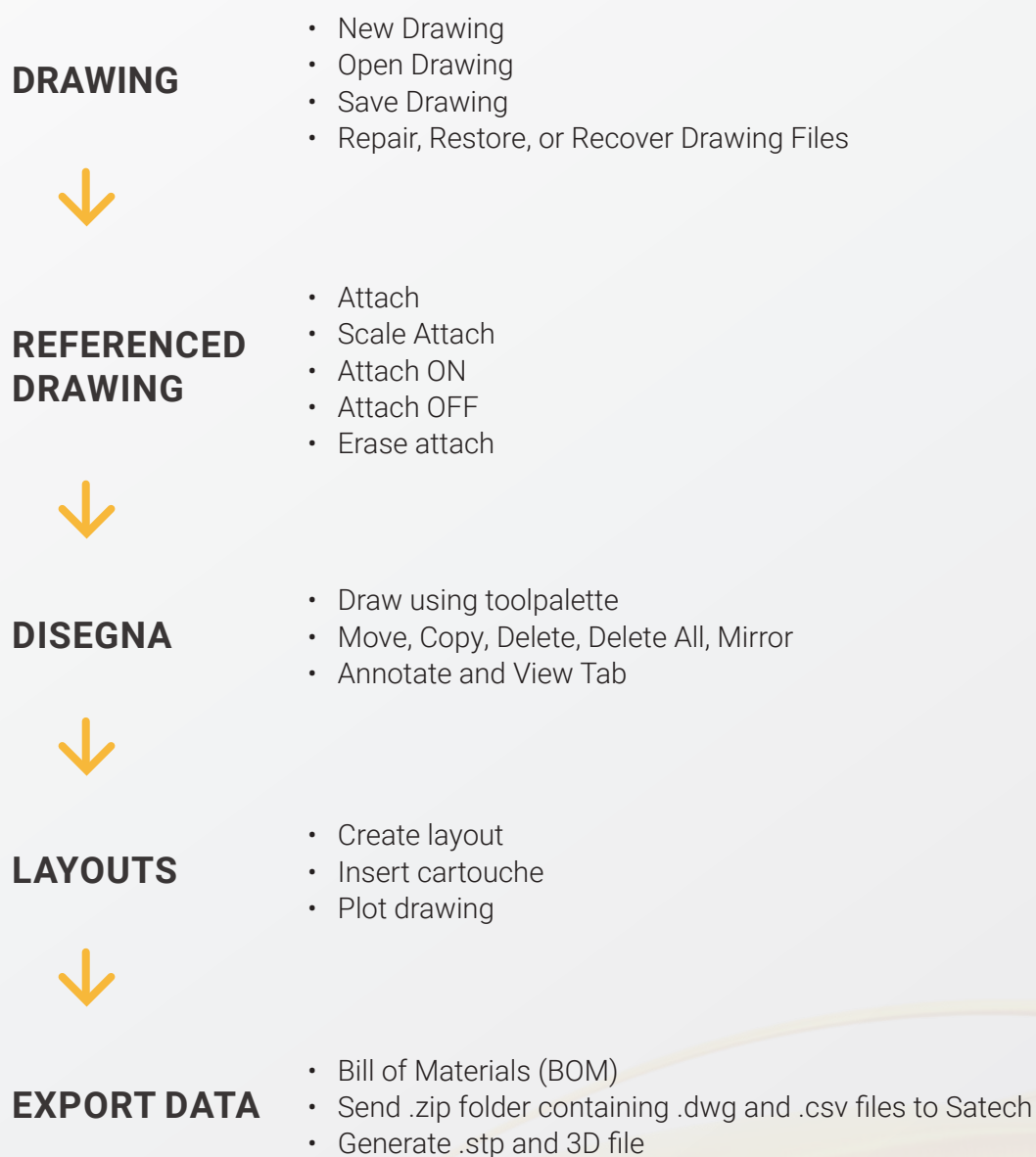

# 5. Onboarding

As you log onto **Disegna 5.0**, an **onboarding pop-up window** will provide guidance on choosing the best Satech System for your needs. You'll be able to acquire information about each Satech System as well as compare them. Follow along the onboarding and get started with your drawing in a few moments!

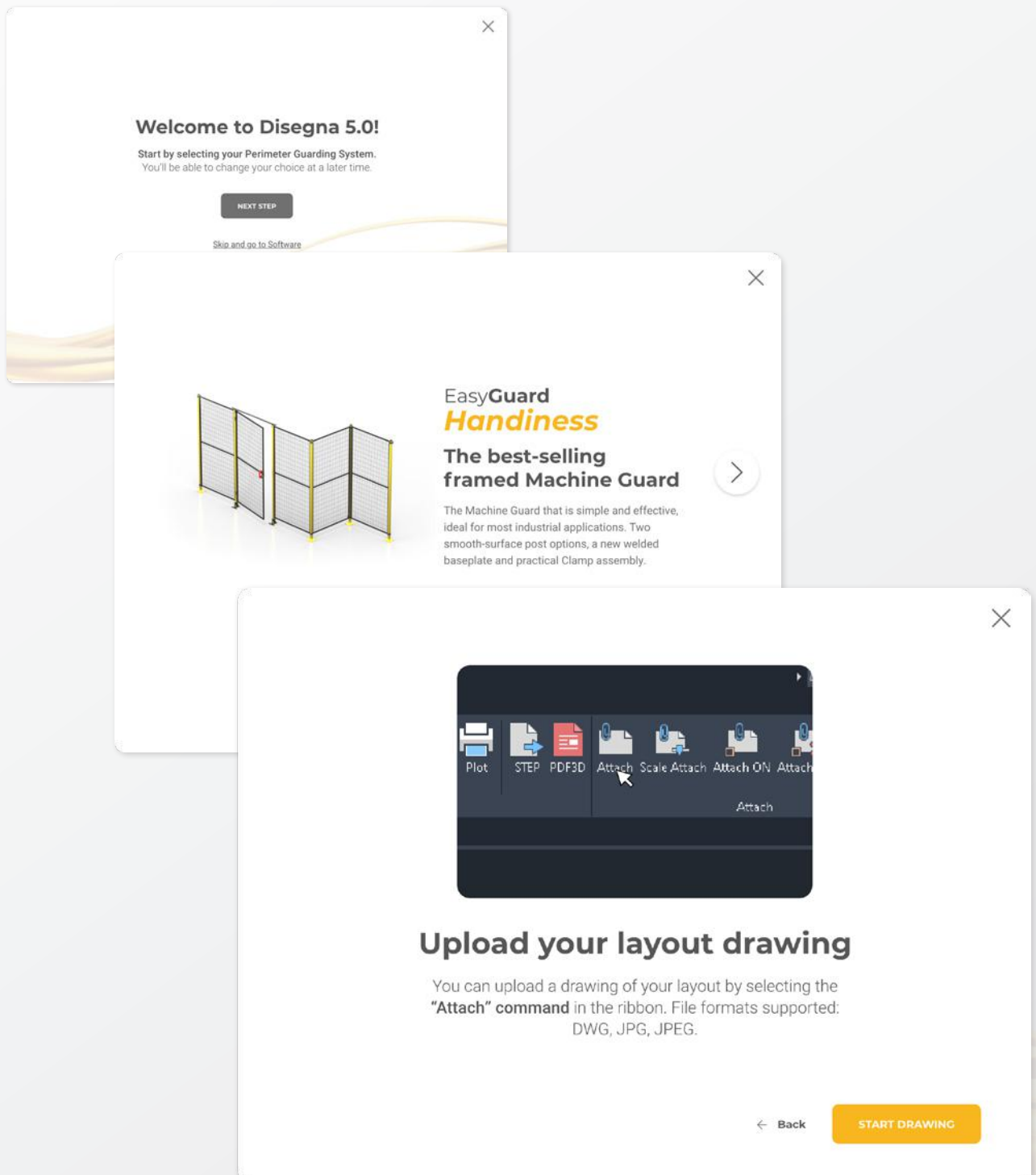

# 6. Starting to Draw

All drawings start from a default drawing template. Drawing template files store default settings, styles, and additional data.

## Open or Save a drawing

You can use several methods to find and open drawings, even damaged drawings. You can save and backup drawings automatically.

You open drawings to work on them just as you do with other applications. In addition, you can choose from several alternative methods. To open a drawing, you can:

- Use *Open* on the File menu to display the Select File dialog box.
- Double-click a drawing in Finder to launch **Disegna 5.0** and open the drawing.

If the program is already running, the drawing opens in the current session.

You save drawing files for later use just as you do with other applications. You can also set up automatic saving and backup files and save only selected objects.

### **When you work on a drawing, you should save it frequently.**

Saving protects you from losing work in the event of a power failure or other unexpected event. If you want to create a new version of a drawing without affecting the original drawing, you can save it under another name.

## Repair, Restore, or Recover Drawing Files

**If a drawing file is damaged** or if your program terminates unexpectedly, **you can recover some or all of the data by using commands to find and correct errors**, or by reverting to a backup file.

A drawing file is marked as damaged if corrupted data is detected, or if you request that the drawing be saved after a program failure. If the damage is minor, sometimes you can repair the drawing simply by opening it.

A recovery notification is displayed while opening drawing files that are damaged and need recovery. You can:

# 7. Referenced Drawing

- **Recover**: performs an audit on, and attempts to open, any drawing file.
- **Audit**: finds and corrects errors in the current drawing.
- **Recoverauto**: controls the display of recovery notifications before or after opening a damaged drawing file.

You can perform several operations on referenced drawing files.



## Attach Commands

You can attach an entire drawing file to the current drawing as a referenced drawing. With the **Attach** commands, changes made in the referenced drawing are reflected in the current drawing. Attached xrefs are linked to, but not actually inserted in, another drawing. Therefore, with xrefs you can build drawings without significantly increasing the drawing file size.

By using referenced drawings, you can:

- **Coordinate your work with the work of others** by referencing other drawings in your drawing to keep up with the changes being made by other designers. You can also assemble a master drawing from component drawings that may undergo changes as a project develops.
- Ensure that **the most recent version of the referenced drawing is displayed**. When you open your drawing, each referenced drawing is automatically reloaded, so it reflects the latest state of the referenced drawing file.

## Attach

You can insert any drawing file as an external reference or xref in the current drawing. When you attach a drawing file as an xref, you link that referenced drawing to the current drawing.



- Click The top View on View Cube;
- The system changes the point of view;
- Click on the “Attach” icon in the Ribbon;
- Select the DWG/JPG file using the dialog window.

The inserted drawing will be similar to this:

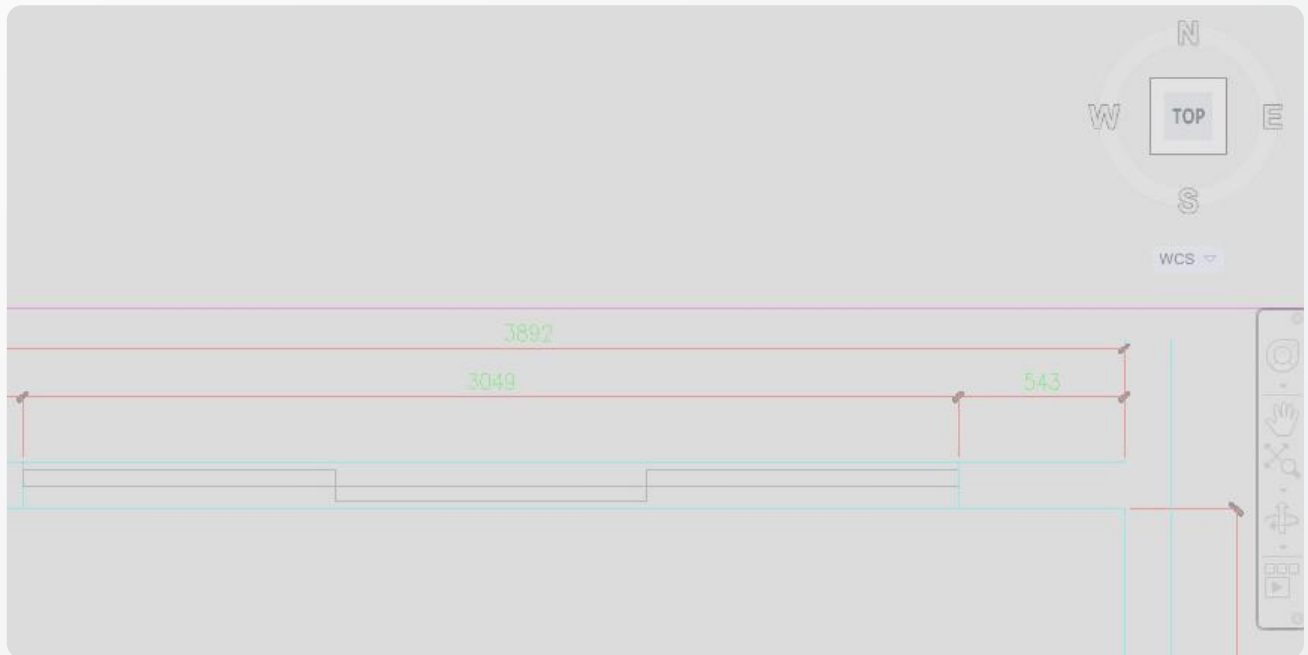

## Determine the Units of Measurement

After you attach the referenced drawing file but before you start to draw, **you must check and decide what one drawing unit represents based on what you plan to draw.** You can convert a drawing between systems of measurement by scaling it.

**Every object you create is measured in drawing units.** Then you create your drawing at actual size with that convention. For example, the objects in the illustration might represent one walls that are each 125 feet long, or a section of a wall that is measured in millimeters. **Disegna 5.0** works in millimeters.

If you start a drawing in one system of measurement (imperial or metric) and then want to switch to the other system, use **Scale Attach** to scale the model geometry by the appropriate conversion factor to obtain correct distances and dimensions.

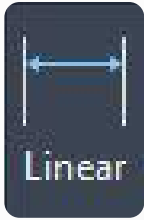

## Scale Attach

You can check that the length of annotation must be the same as the measurements you can insert in the drawing. Use the command Linear in the Tab annotate to check the length.

If the distance is different, **you must use the *Scale Attach* button.**

You can specify the size of dimensions in your drawing. How you set dimension size depends on the method you use to lay out and plot drawings.

**Dimension scale affects the size of the dimension geometry** relative to the objects in the drawing. Dimension scale affects sizes, such as text height and arrowhead size, and offsets, such as the extension line origin offset.

You should set these sizes and offsets to values that represent their actual plotted size.

To do this operation, click on the *Scale Attach* button.

1. Click the point where you want to start the annotation:

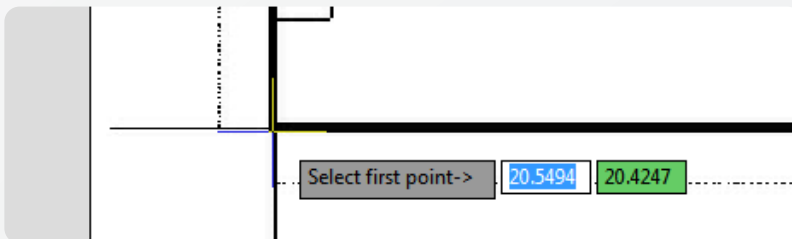

2. Click on the end point of the line:

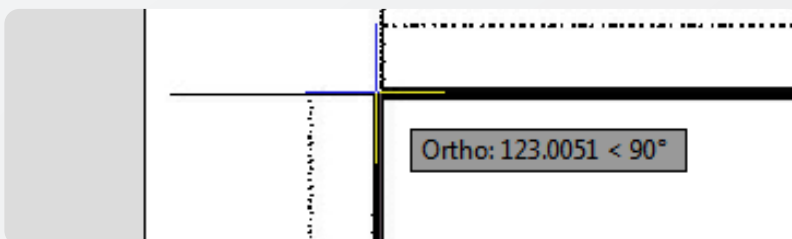

3. Insert the right measure (as the same as you read in the attachment)

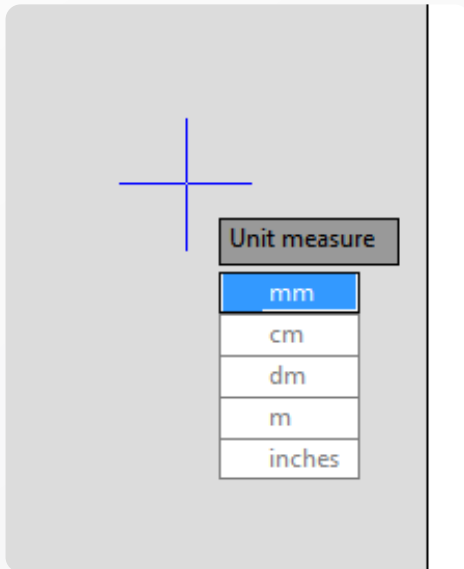

4. Input the measure unit you use to set the distance

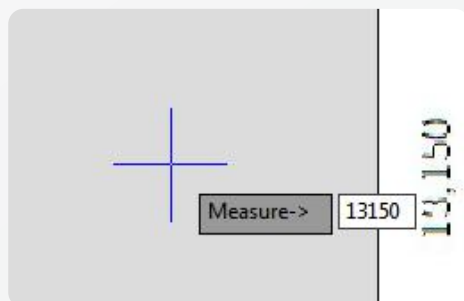

**You're able to draw on your attach using the right scale.** If you have problems to see the color of the cursor, you can easily change the color of the mouse (appendix A).

## Attach ON - Attach OFF

**When a referenced drawing (xref) is unloaded from the current drawing, the drawing opens much faster and uses less memory.**

The xref definition is unloaded from the drawing file, but the internal pointer to the referenced drawing remains. The xref is not displayed, and nongraphical object information does not appear in the drawing. However, you can restore all the information by reloading the xref.

You should unload a reference file if it is not needed in the current drawing session but may be used later for plotting. You can maintain a working list of unloaded xrefs in the drawing file that you can load as needed.

## Erase Attach

**To completely remove DWG references (xrefs) from your drawing, you need to detach them rather than erase them.**

Erasing xrefs does not remove, for example, layer definitions associated with those xrefs. Using the Erase option removes the xrefs and all associated information.

# 8. Drawing a Perimeter

## Drawing a Perimeter Protection

To draw a Perimeter Protection, you have to choose in the Tool Palettes the type of the protection you want to draw. To switch between the various Systems and Products available, just use the tabs in the side panel.

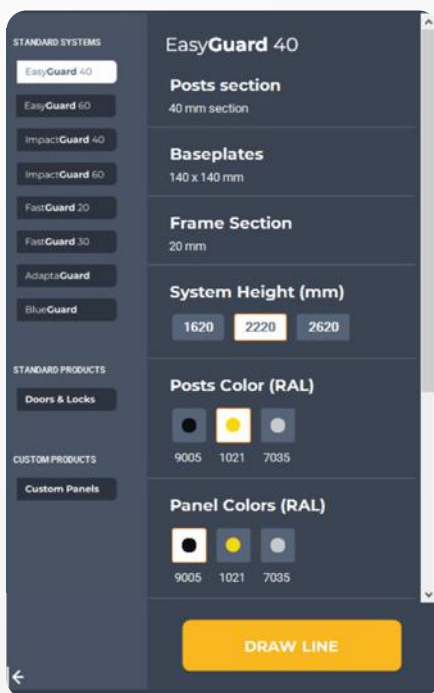

- Select the height of the System
- Select the color of Posts and Panels
- Select Panel options among the ones available
- Press the **DRAW LINE** button at the bottom.

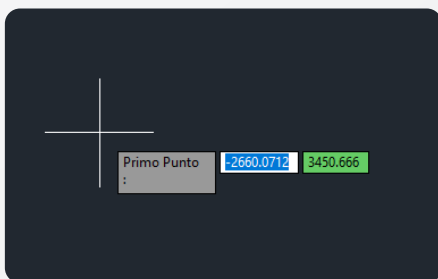

You are all set to start drawing your perimeter.  
**Move the cursor on the Drawing Area.**

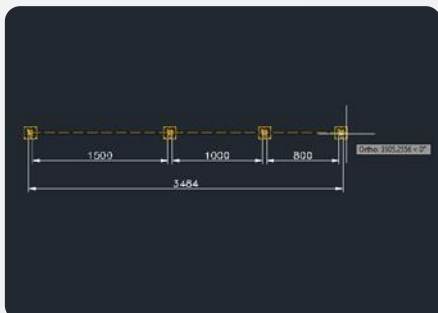

When you pick the first point and move the cross-hairs to the location of the second point, **you will see a rubber line which shows you where the line will be drawn** when the second point is picked or when you insert via keyboard the length of the line. Line objects have two ends (the first point and the last point). You can click the end point or manually input the length of the line.

## Ortho Mode

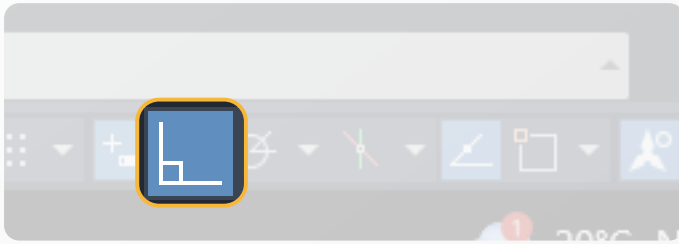

**Ortho** is short for “orthogonal”, which means either vertical or horizontal. Like the other options on the status bar, Ortho is not really a command -- rather, **it is a drawing mode which can either be turned on or off**. Ortho mode can be toggled on or off in one of three ways. The quickest way is just to click on the ORTHO button on the status bar.

The appearance of the button tells you whether the orthogonal mode is currently turned on or turned off. **When it is turned on, the ORTHO button state appears to be pressed.**

Ortho can also be **toggled on and off using the F8 Function key**.

## Positioning of Panels and Posts

A very important concept to keep in mind is that **Disegna 5.0 automatically calculates the positioning of the Panels and of the Posts in the line**.

According to the distance from the first point clicked by the user and the current point, **Disegna 5.0 calculates the best solution to fit that distance using the Panels with Standard sizes**. The measure of Standard Panels and the section of the Posts are strictly related to the type of System selected to draw the perimeter.

## Adding Doors to the Perimeter

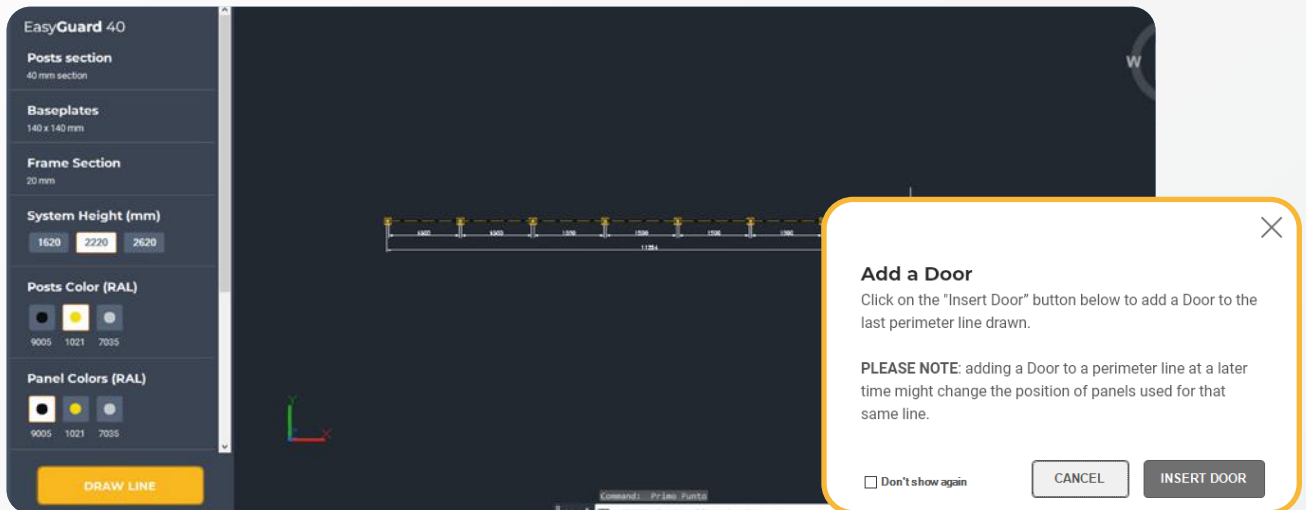

After you end drawing a perimeter line, **Disegna asks you to add a Door via a pop-up window** located in the bottom-right corner of the Drawing Area.



**We strongly recommend inserting the Door right away via the "Insert Door" button,** as inserting a Door (or a Custom Panel) after having drawn the entire perimeter can alter the composition of the Perimeter itself. Keep in mind that Disegna re-calculates the composition of Panels in your Perimeter everytime you add a Door, a Custom Panel or simply edit existing Panels.

**The "Add a Door" pop-up appears at the end of each perimeter line drawn.** If you wish to skip this step, you can flag the "Don't show again" checkbox Option in the bottom left corner of the pop-up. This will prevent the message from appearing for the remainder of the session.

If a user decides not to add a door after all, they can simply click on the "Cancel" button to exit the window and return to the main design interface.

## Drawing a Door

Another way of adding a Door is by selecting the tab "Doors" in the toolpalette.

**The "Doors & Locks" module allows users to customize Doors** within their design, offering choices on type, variant and door opening width.

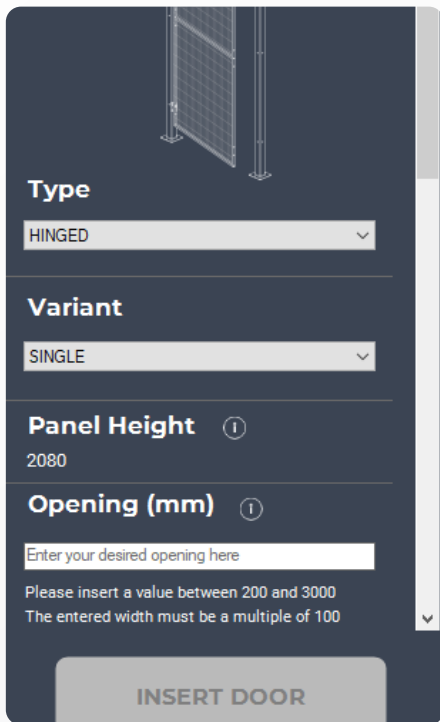

1. Choose the type of the Door from the dropdown;
2. Choose its variant;
3. Check the panel height;
4. Set its opening in mm. Ensure the entered value is between the values mentioned by the helper text beneath the input field. **Additionally, the width should be a multiple of 100 mms for it to be valid.**
5. Single click on the button “**INSERT DOOR**”;
6. Move the mouse near the point you want to insert the Door.

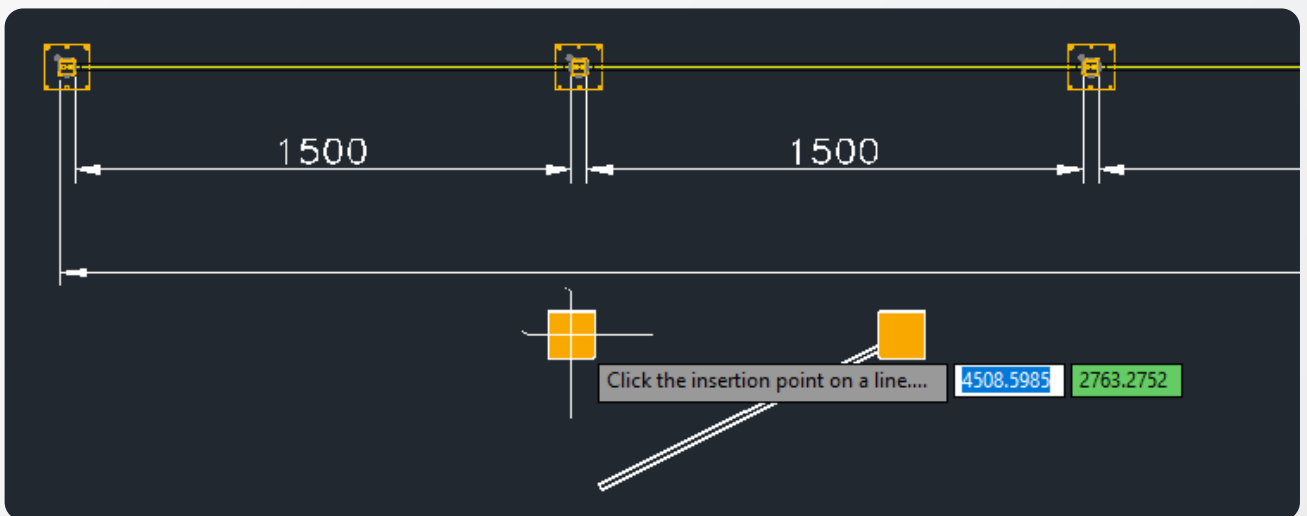

Once the **INSERT DOOR** function is activated, a preview of the Door will appear on your cursor. Move the cursor to the desired location where you intend to place the Door. The Door preview will move with your cursor, giving you a visual representation of the Door’s placement.

As you approach a Perimeter line with the Door preview, the software will automatically align the Door with the fence. **This ensures that the Door is perfectly placed within the design**, maintaining the integrity and safety of the Machine Guard.



The Door will snap to the fence line, providing a visual confirmation of its correct alignment. Exit the window and return to the main design interface.

The measure near the cursor is the distance between the start of the line and the first Post of the Door. Once you are satisfied with the Door's position, **click on the desired location to insert the Door into your design**. Instead of clicking, you can also digit the distance using the keyboard and the press Enter.

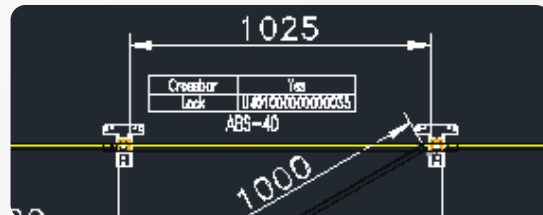
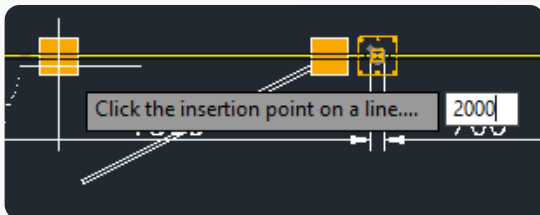

The Door will be inserted, and the preview will disappear.

## Drawing Custom Panels

**Disegna 5.0** also enables you to draw Panels with Custom sizes, as well as cutout shapes. These Panels can be inserted in any place of your Perimeter line. Access the **Custom Panels** tab in the lateral menu and set your Custom Panel in a few, simple clicks:

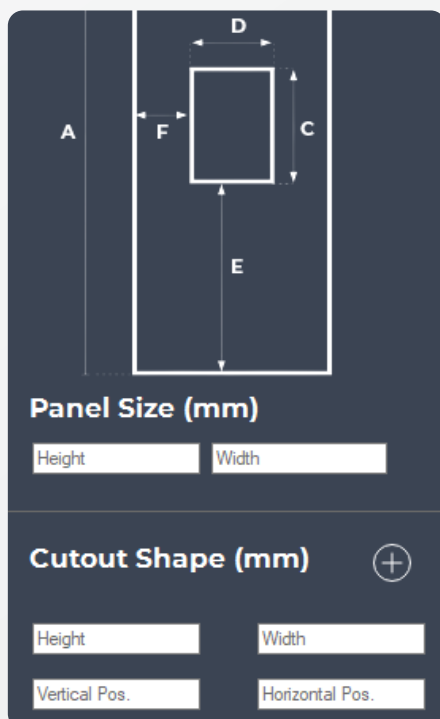

1. On the left side, under **Panel Size (mm)**, you will see input fields for **Height** and **Width**. Enter the desired dimensions for your custom panel in these fields.

2. In order to create a Cutout Shape, click on the plus button. Use the **Height** and **Width** fields to determine the size of your cutout, as well as the **Vertical** and **Horizontal Position** fields to position the cutout shape within the Panel.

*Tip: a Vertical Position set to zero will generate a cutout shape stuck to the bottom side of the Custom Panel, while a Horizontal Position set to zero will generate a cutout shape stuck to the left side of said Custom Panel.*

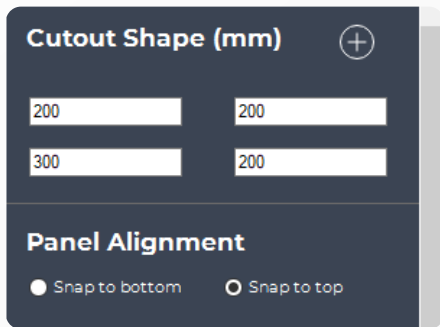

3. Panel Alignment: under the **Panel Alignment** section, you have the option to set the Panel's vertical alignment in relation to the other Panels in the Perimeter. Choose **Snap to bottom** to align the panel to the bottom side or **Snap to top** to align it to the top side. Once you have inserted the Panel, you'll be notice the selected alignment on the Perimeter.

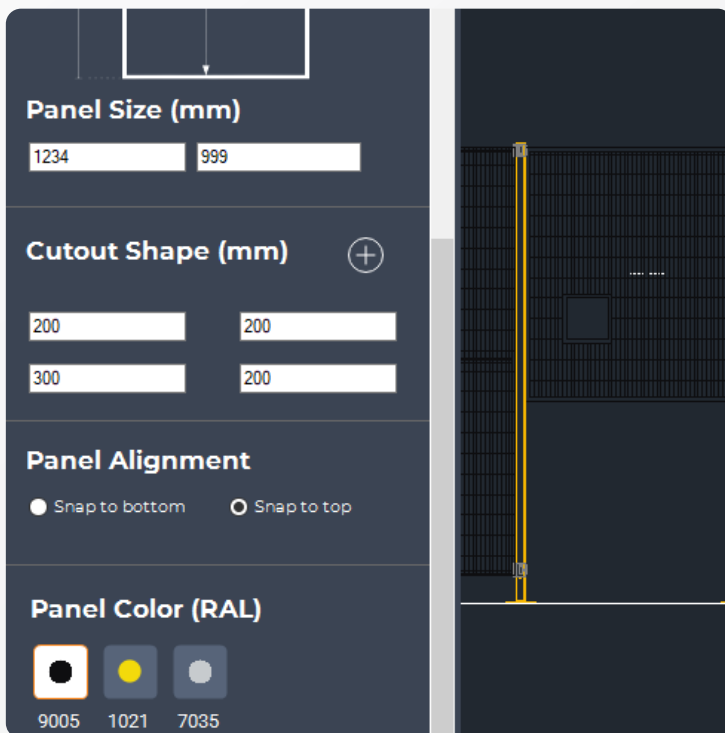

Once you're satisfied with your custom panel's settings, click on the **INSERT PANEL** button and hover your cursor over the desired location in your Drawing. Similar to the Door insertion, a preview of the panel will appear, allowing you to visualize its placement.

When the preview panel aligns with the perimeter line, click to confirm its position. Congratulations, you have successfully inserted a Custom Panel on your Satech Perimeter Guarding!

## Making changes

You can backtrack your recent actions in a variety of ways.

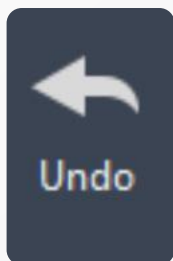
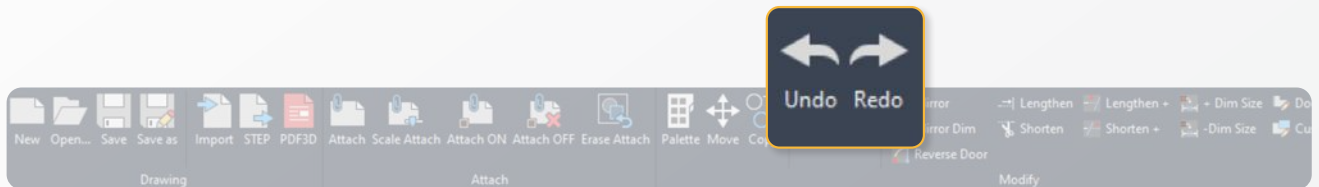

### 1. Using the Undo and Redo button

The simplest method of backtracking an action is to use the **Undo** command to undo a single action. Many commands include their own U (undo) option so that you can correct mistakes without leaving the command. You use the Undo Command by clicking its icon in the Ribbon.

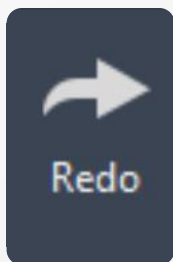

You can also reverse the effect of a single U or Undo command by using **Redo** immediately after. You can also redo several actions at once with the Redo list on the Standard toolbar. To activate the Redo Command, click its icon in the Ribbon.

## 2. Editing a Door/Custom Panel

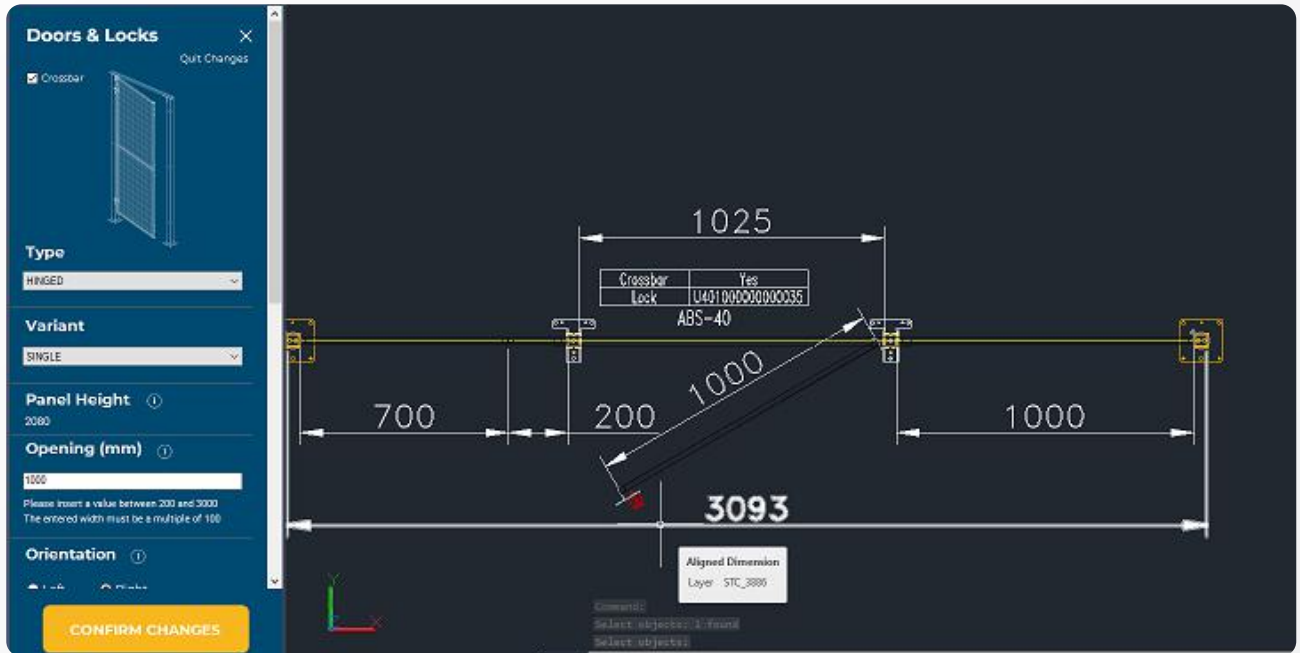

In the *Doors & Locks* module, you have the ability to edit the properties of a Door Panel. The following guide will take you through the steps required to make modifications to a selected Door Panel.



1. **Access the Edit Mode.** Look for the pencil icon located in the upper right corner of the *Doors & Locks* module. This icon represents the “Edit” function.

2. Selecting a Door Panel:

- If you've previously selected a Door Panel, clicking the pencil icon will immediately put you in Edit Mode for that specific Door Panel.
- If no Door Panel has been selected, upon clicking the pencil icon, you will be prompted to select a Door Panel. Simply click on the desired Door Panel you wish to modify.

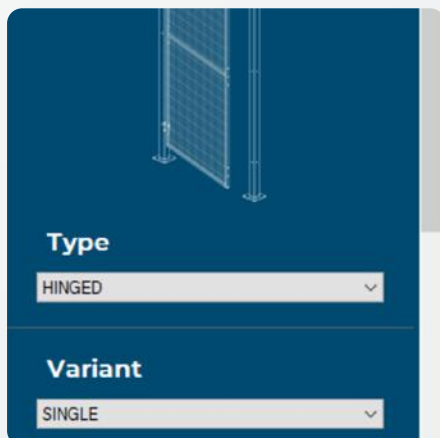

You will notice a change of background color, turning to **blue**: your visual cue that you have entered the Edit Mode.

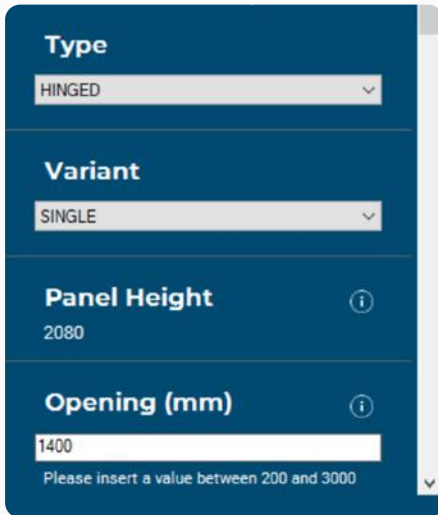

3. **Modifying Door Properties:** once in the Edit Mode, click on the drop-down menu next to Type to modify the Type of Door (e.g. "Hinged"). You'll also be able to modify the Variant of Door selected (e.g. "Single"), as well as the Panel Height. You can do the same with the Door Opening by entering the desired opening width for the door in millimeters. However, keep in mind that **the width must still be a multiple of 100 mm and must it in the range indicated by the helper text beneath the input field** (e.g. between 700 and 1500 mm).



4. **Save Changes:** after making the desired modifications, click "CONFIRM CHANGES" to save your changes. This will update the door panel with the new properties.

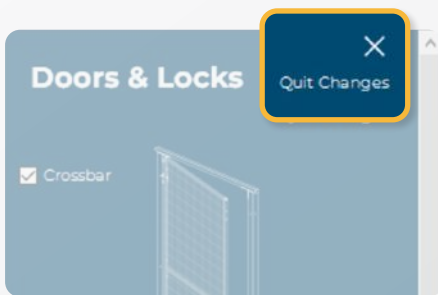

On the contrary, if you'd like to discard the changes done to the Door/Custom Panel, you can click the "Quit Changes" button located close to the panel title.

### 3. Deleting a Line

You can delete a single Line by **clicking the icon in the Ribbon** and then **clicking the baseline of the Perimeter Guard**.

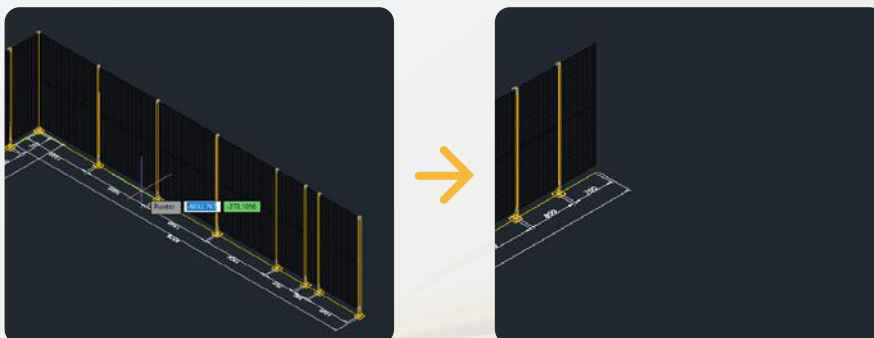
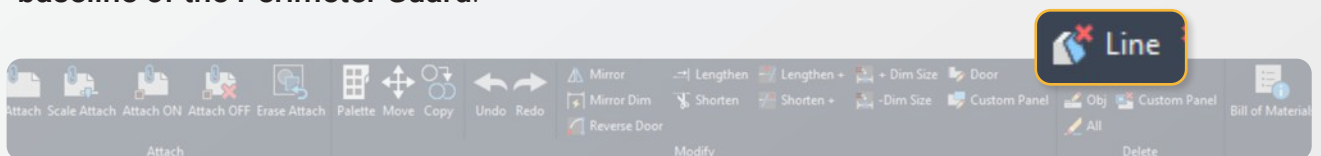

## 4. Deleting all objects



You can delete all components in a drawing by clicking the icon Delete All.

## 5. Copy and Move

You can create duplicates of objects at a specified distance and direction from the originals. **Copy a Perimeter line using the distance and direction specified by a base point** followed by a second point.

Select the original perimeter protection to be copied. **Disegna 5.0** automatically specifies the base point for the move (1) followed by a second point (2). The line is copied the distance and direction of point 1 to point 2.

The Move Command works like Copy, but it moves the line from the first point to the second.

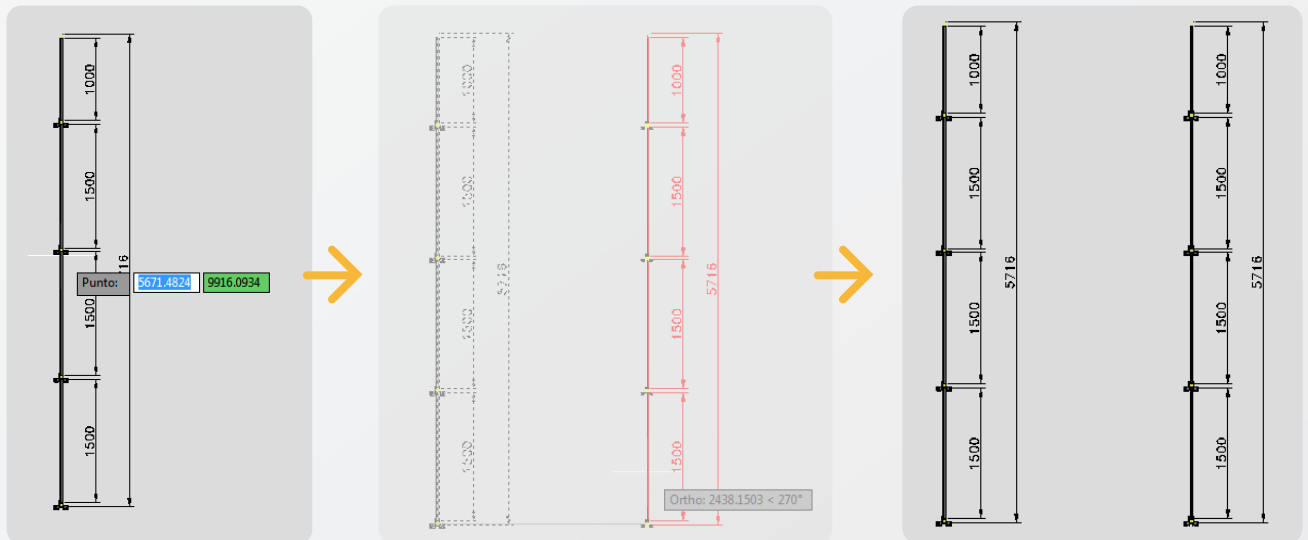

# 9. Exporting a Bill of Materials

Disegna 5.0 provides an efficient and user-friendly method to export your Bill of Materials (BoM). Whether you wish to have a backup or share your BoM with colleagues or clients, the export feature ensures you can do so with just a few clicks.

Here is how you can export Your Bill of Materials:

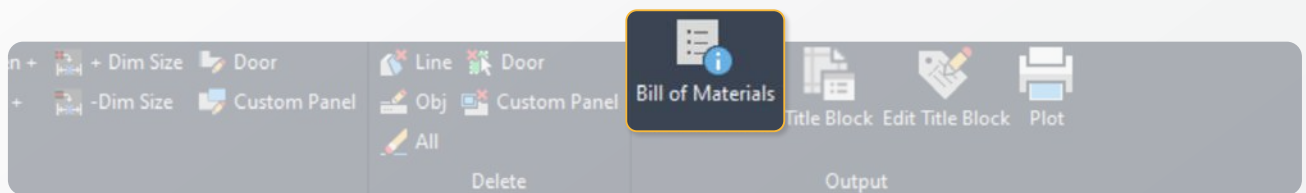

## 1. Locating the BoM export button

In the Ribbon find the Bill of Materials Button and click it. A pop-up window will appear.

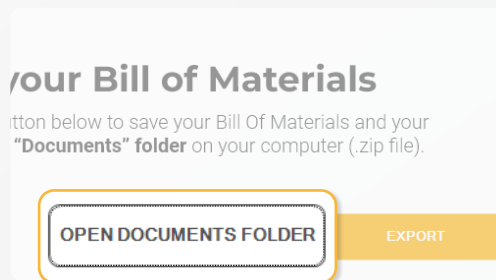

## 2. Opening Documents Folder

Before exporting, if you wish to check your default "Documents" folder, click on the **OPEN DOCUMENTS FOLDER** button. This will launch the folder where your exported file will be saved by default.

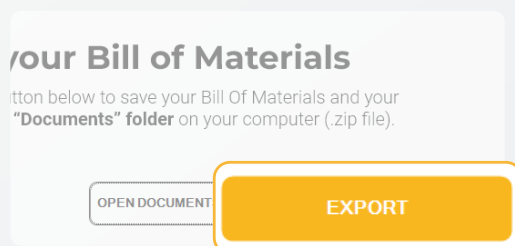

## 3. Exporting your BoM

Click the **EXPORT** button. The software will then compile your Bill of Materials and export it in a .zip folder inside your Documents folder, on your computer together with a .dwg file of your Perimeter.



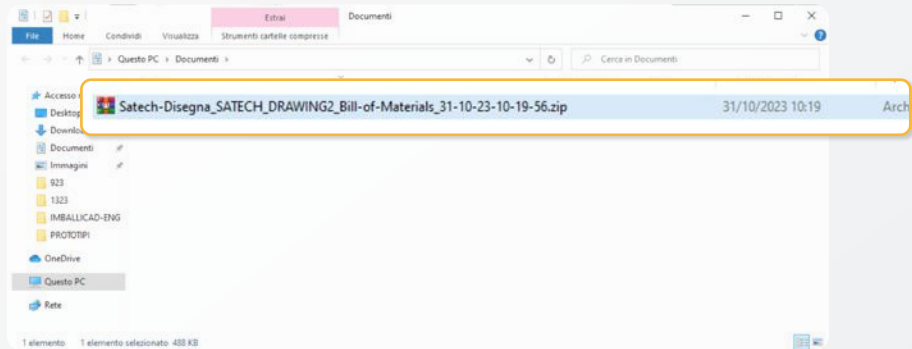
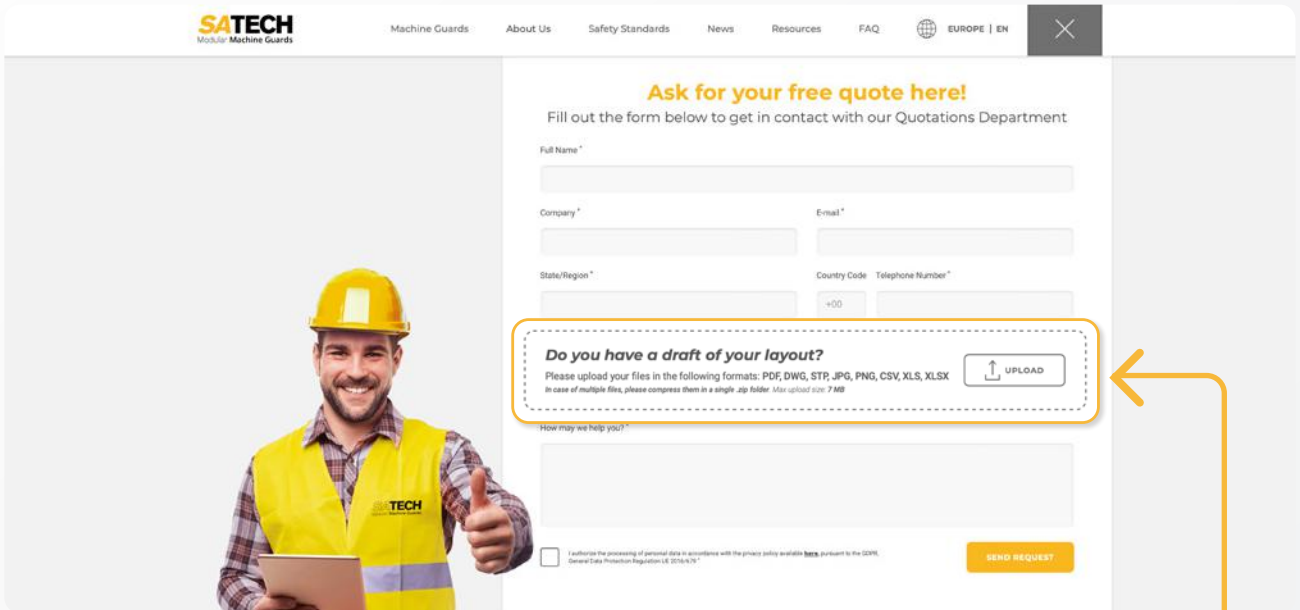

#### 4. Request your free quotation

You can now upload the exported .zip file from the **Disegna 5.0** window and upload it in the [Quick Contact Form on the Satech Website](#).

**You will receive a free, no-obligation quote for the Perimeter layout you drew!**



For information, installation  
support and general assistance:

**[disegna@satech.it](mailto:disegna@satech.it)**

